

NOTES:

- 1. SUBSTRATE:  
FUSED SILICA
  
- 2. COATING (APPLY ACROSS CLEAR APERTURE)

S1: Ravg ≥78% @ 120 - 125nm  
 Ravg ≥85% @ 120 - 600nm  
 S2: COMMERCIAL POLISH

3. FINE GRIND SURFACE

4. ROHS COMPLIANT

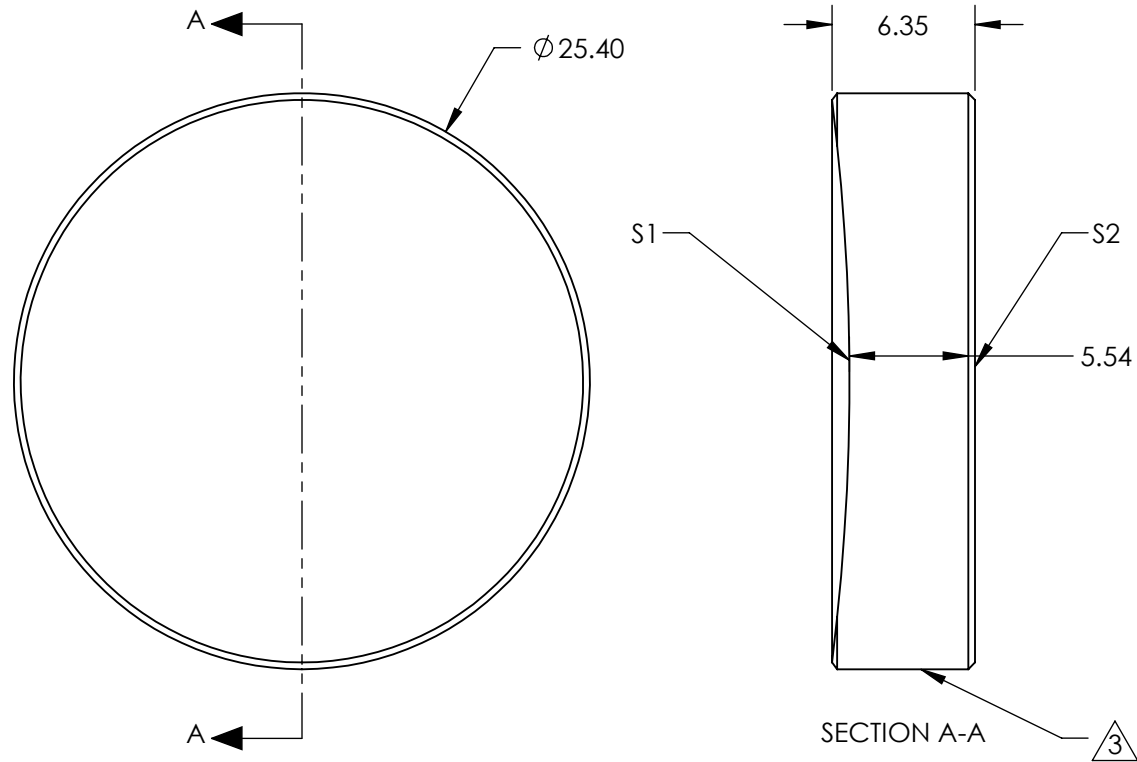
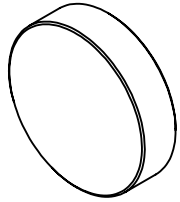

**FOR INFORMATION ONLY:  
 DO NOT MANUFACTURE  
 PARTS TO THIS DRAWING**

SPECIFICATIONS SUBJECT TO CHANGE WITHOUT NOTICE  
 DIMENSIONS ARE FOR REFERENCE ONLY

	S1	S2
SHAPE	CONCAVE	PLANO
SURFACE QUALITY	20-10	N/A
COATING TYPE	METAL	N/A
COATING	Enhanced Aluminum (120-600nm)	N/A
BEVEL	PROTECTED AS NEEDED	PROTECTED AS NEEDED

THIRD ANGLE PROJECTION

ALL DIMS IN

mm

**EO**® Edmund Optics®

TITLE

25.4mm Dia., 50mm FL, Vacuum UV (VUV)  
 Spherical Mirror

DWG NO

24057

SHEET  
 1 OF 1